

Grundfos LiqTec protects against dry running

Dry running ruins the best of pumps in only seconds

What can you do before it's too late? The Grundfos LiqTec protects against dry running. It's a new accessory from the leaders in pump technology.

Grundfos LiqTec stops the pump before damage occurs

The LiqTec sends a heat pulse through a sensor measuring the sensor's own temperature. If there is liquid in the pump, the sensor is cooled like the shaft seal and other internal pump parts. If there is no liquid in the pump, LiqTec detects a high temperature in the sensor and shuts the pump down immediately.

Easy installation, Instant peace of mind

Grundfos LiqTec is "plug-and-play" technology at its best. The sensor is easily inserted through the pump head close to the shaft seal. Plug in the electronic control unit and turn on the power for instant peace of mind.

Additional features:

- **Restart manually or automatically** when the sensor detects water in the pump again. Remote restart via a PC is possible via a digital port to the electronic control unit.
- **Overheating protection is available** when you connect the electronic control unit to the pump motor thermostat. LiqTec takes over the function of a PTC sensor.
- **Durability you can depend on:** the sensor can tolerate the same level of corrosives as the pump itself.



Grundfos LiqTec is your best insurance against dry running

Easy to install and designed for your peace of mind, LiqTec joins our redesigned CR series that brings you new solutions for:

- high pressure
- high/low viscosities
- shaft seal solutions for "difficult" liquids
- surface treatments
- high/low liquid temperatures
- special motor configurations

Grundfos offers great customer service throughout the world

Our efficient world-wide service network stands by you with experienced technicians and spare parts, when and where you may need them.

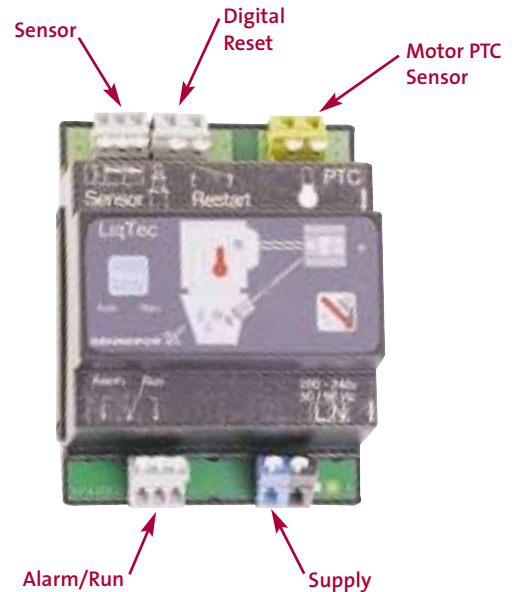

Technical Data

Power Supply:	1 x 115V 50/60 Hz 1 x 200-240V 50/60 Hz
Power consumption:	5 watts
Max. pressure:	580 psi [40 bar]
Max. liquid temp.:	250° F [120° C]
Max. ambient temp.:	131° F [55° C]
Humidity:	99%
Liquids:	Any liquid handled by Grundfos pumps
Cable length:	49 ft [15m]

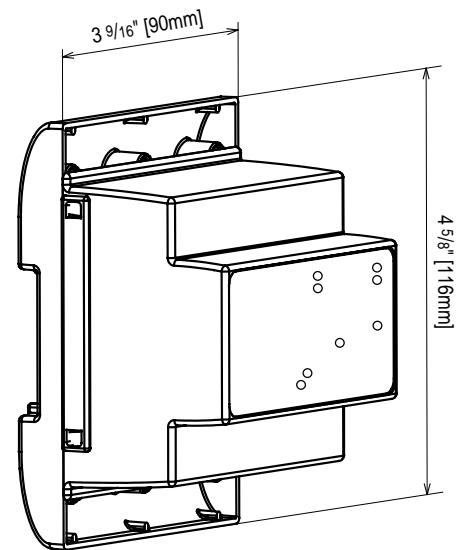

Product Numbers

Complete unit (115v):	96463912
Complete unit (200-220v):	96443674
Sensor unit service kit:	96443675
Ext. cable kit:	96443676

Patent Pending

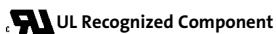

L-SMCR-SL-003 9/01
 PRINTED IN USA